

KALLER®



New!
CU 420, CU 740 & CU 2900



Super Compact CU 420-18300

by

 **STRÖMSHOLMEN**

Dimensions

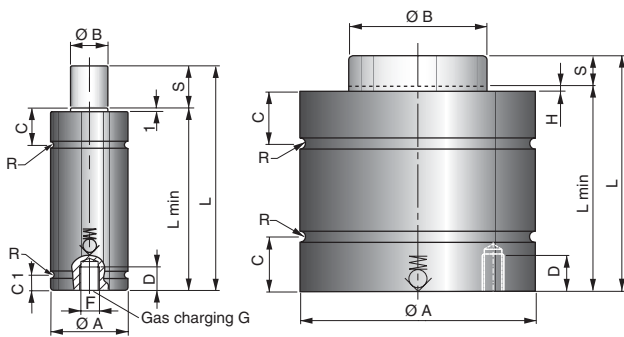

CU 420 - CU 740

CU 1000 - CU 18300

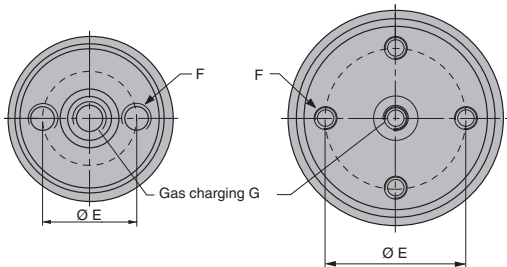

Bottom view
CU 740 - CU 2900

Bottom view
CU 4700 - CU 18300

CU gas springs are very compact bore sealed springs, which provide the highest force per cylinder diameter.

CU gas springs are ideal where space is limited in the die and very high forces are required.

CU gas springs can be linked together and charged remotely using a control block and hose system. Repair kits are also available for all CU models except the CU 420 and CU 740.

For more information, see our main KALLER catalogue.

Mounting options

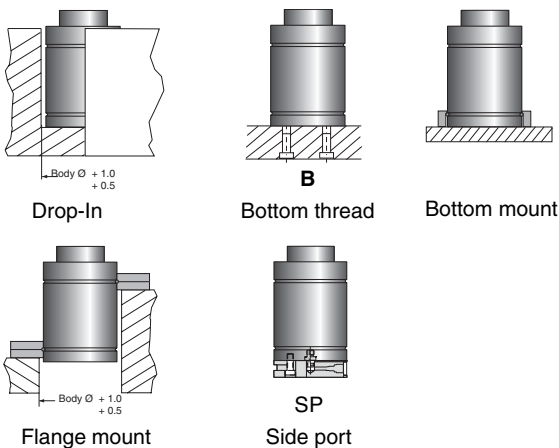

Model	Drop in	B	Bottom mount		Flange mount				SP
			BFCU	BFP	FC	FCS FCX	FCR	FK	
CU 420	X	X					X		
CU 740	X	X			X				
CU 1000	X	X	X		X	X			X
CU 1800	X	X	X		X	X			X
CU 2900	X	X				X			X
CU 4700	X	X		X				X	X
CU 7500	X	X		X				X	X
CU 11800	X	X	X		X	X			X
CU 18300	X	X	X		X	X			X

X = Mount is available for this model

Basic Information

Pressure medium	Nitrogen
Max. charging pressure	150 bar
Min. charging pressure	25 bar
Operating temperature	0 - +80°C
Force increase by temperature	±0.3%/°C
Recommended max strokes/min	~ 100 (at 20° C)
Max piston rod velocity	0.5 m/s
Repair Kit	Available for model sizes CU 1000 to CU 18300

Note! See main catalogue for more information.

Initial force

Calculation of charge pressure for CU, to achieve desired initial force:

X = Desired initial force in N

$$\text{Charge pressure} = 150 \cdot \frac{X}{\text{Initial force at 150 bar}}$$

Example: CU 4700 to have a desired initial force of 25000 N

$$\text{Charge pressure} = 150 \cdot \frac{25000}{47000} \approx 80 \text{ bar}$$

Dimensions

Order No.	S Stroke	Force in N at 150 bar/+20°C		L ± 0.25	L min	Ø A ±0.1	Ø B	C/C1	D	Ø E	F	G	H	R
		Initial	End force**											
CU 420-006	6	4250	7000	56	50	24.9	12	11.5/5	5	--	M6	M6	1	1
CU 420-010	10		6900	70	60									
CU 420-016	16		6900	91	75									
CU 420-025	25		6900	120	95									
CU 420-032	32*		7600	140	108									
CU 420-040	40*		7600	165	125									
CU 420-050	50*	7600	195	145										
CU 740-006	6	7400	9800	63	57	31.9	20	11.5/10.5	5.5	15	M6	M6	1	1
CU 740-010	10		10000	75	65									
CU 740-016	16		11000	93	77									
CU 740-025	25		12000	120	95									
CU 740-032	32*		12000	140	108									
CU 740-040	40*		12000	165	125									
CU 740-050	50*	12000	195	145										
CU 1000-06	6	10600	16000	61	55	37.9	20	10.5	6.5	17	M6	M6	0.5	1
CU 1000-10	10		16000	78	68									
CU 1000-16	16		16000	100	84									
CU 1000-25	25		16000	135	110									
CU 1000-32	32*		16000	167	135									
CU 1000-40	40*		16000	195	155									
CU 1000-50	50*	16000	230	180										
CU 1800-06	6	18000	25000	66	60	50.2	30	14.5	6.5	26	M6	G1/8"	0.5	2
CU 1800-10	10		26000	80	70									
CU 1800-16	16		26000	106	90									
CU 1800-25	25		27000	135	110									
CU 1800-32	32*		27000	162	130									
CU 1800-40	40*		28000	190	150									
CU 1800-50	50*	29000	220	170										
CU 2900-010	10	29500	38500	85	75	63.2	45	19/18	9	34	M8	G 1/8"	1	2
CU 2900-016	16		41000	103	87									
CU 2900-025	25		43000	130	105									
CU 2900-032	32*		44200	150	118									
CU 2900-040	40*		45200	175	135									
CU 2900-050	50*		45800	205	155									
CU 4700-10	10	47000	67000	80	70	75.2	50	18	9	40	M8	G1/8"	0.5	1.5
CU 4700-16	16		66000	106	90									
CU 4700-25	25		68000	135	110									
CU 4700-32	32*		67000	167	135									
CU 4700-40	40*		67000	200	160									
CU 4700-50	50*		67000	240	190									
CU 7500-10	10	75000	104000	90	80	95.2	55	21	9	52	M8	G1/8"	0.5	1.5
CU 7500-16	16		104000	116	100									
CU 7500-25	25		109000	145	120									
CU 7500-32	32*		105000	182	150									
CU 7500-40	40*		107000	210	170									
CU 7500-50	50*		106000	255	205									
CU 11800-10	10	118000	155000	100	90	120.2	70	22.5	11	68	M10	G1/8"	0.5	2.5
CU 11800-16	16		158000	126	110									
CU 11800-25	25		170000	155	130									
CU 11800-32	32*		164000	187	155									
CU 11800-40	40*		165000	220	180									
CU 11800-50	50*		166000	260	210									
CU 18300-10	10	184000	235000	110	100	150.2	90	24.5	11	90	M10	G1/8"	0.5	2.5
CU 18300-16	16		252000	136	120									
CU 18300-25	25		254000	165	140									
CU 18300-32	32*		251000	197	165									
CU 18300-40	40*		250000	235	195									
CU 18300-50	50*		255000	270	220									

New!

New!

New!

Note! * For stroke lengths over 25 mm, the spring should be attached to the tool using the tapped holes in the bottom or using flanges. We also recommend shorter stroke springs to be fastened for optimal service-life.
** At full stroke

KALLER®

The Safe Choice

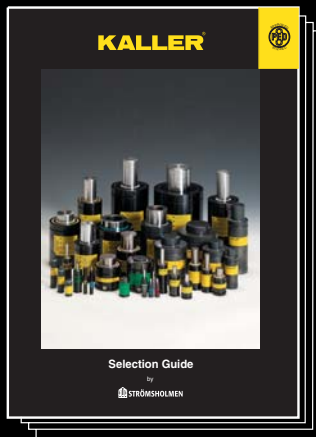

Gas Springs

Kaller developed the first nitrogen gas spring for press tools and today offers a comprehensive selection of high quality gas springs for use in different tool & die applications.



Controllable Gas Springs-KF2

Kaller controllable springs are a family of gas springs, for use in press tools, that can be locked in their bottom position and where the return stroke of the spring can be controlled.



Flange Stripper Unit

Kaller Flange Stripper Unit is used in flanging dies for stripping/lifting a flanged part after forming. It provides 200 daN of stripping force, can be top or bottom mounted and is self guiding.



Flex Cam™

The Flex Cam is used for piercing, cutting, forming and flanging operations. The system allows for a flexible distribution of forces with optimal direction and velocity. By using a Flex Cam, fewer tools are required in production.



Roller Cam

Kaller Roller Cam is used for piercing, trimming, flanging and restriking. The Roller Cam can be mounted in both vertical and horizontal angles.



Counter Balance

Kaller Counter Balance gas springs can be used to lift, lower, assist, balance, and hold in a multitude of applications.

 **STRÖMSHOLMEN**
Strömsholmen AB

Box 216 • SE-573 23 Tranås • Sweden
Phone +46 140-571 00 • Fax +46 140-571 99
info@kaller.com • www.kaller.com

 **KALLER®**
GAS SPRINGS

33280 Groesbeck Highway, Fraser,
MI 48026

Phone: +1 586 415 6677, Fax +1 586 415 6699